

DALI POWER SUPPLY 100W 12V 24V IP20

TECHNICAL SHEET
AZ-DALI-12/24100

FEATURES

- 100-130/170-264VAT
- Protection: Shortcircuit/overload/overvoltage
- Working temperature with 60°C
- Cooling by free air convection
- 100% full load burn-in test
- 3 years warranty
- Support: DALI



SPECIFICATIONS

Model		AZ-0/10-12100	AZ-0/10-24100
Output	DC Voltage	12V	24V
	Voltage Tolerance	±0.5V	
	Rated Current	0-8.3A	0-4.2A
	Rated Power	100W	
Input	Ripple & Noise	150mvp-p	
	Voltage Range	200-240VAC	
	Frequency Range	50-60HZ	
	Power Factor	PF≥0.5/230VAC (Full Loading)	
	Full Load Efficiency(Typ)	85%	
	AC Current(Max.)	1.22A	
	Leakage Current	<0.5mm A/260VAC	
Protection	Inrush Current	≤60A	
	Short Circuit	Protection type: Hiccup mode, recovers automatically after fault condition is removed	
	Over load	Hiccup mode, recovers automatically after fault condition is removed	
	Vibration	10-500HZ 2G 10min	
Environment	Burnt-in test	Input Voltage: 220V 50HZ Rated Output current 25°C Burn-in 2H	
	Over Temperature	100°C ±10°C Shut down o/p Voltage, re-power on to recover	
	Working TEMP	-20 +50°C	
	Working Humidity	20~60%RH, Non-condensing	
	Storage TEM, Humidity	-20~+85%, 10~95RH	
Safety & EMC	Start Rise Hold Time	1500ms, 20ms, 50ms/230VAC at full load	
	Vibration	10-500HZ, 5G 12min/1cycle, period for 60min, each along X,Y,Z axes	
	Safety Standards	CE Mark	
	Withstand Voltage	I/P-O/P: 1.5KVAC I/P-GND: 1.5KVAC	
Others	EMC Immunity	EN55015:2013; EN61547:2009; EN61000-3-2; 2014; EN61000-3-3; 2013	
	Weight	0.36KG	
	Dimension	231.6*49*29mm(L*W*H)	
Notes	Packing	50Pcs/CTN	
	<p>1- All parameters NOT specially mentioned are measured at 230VAC Input, rated load and 25°C of ambient Temperature. 2- Tolerance: includes set up tolerance, line regulation and load regulation. 3- The power supply is considered as a component that will be operated in combination with final equipment, since EMC performance will be affected by the complete installation, the final equipment manufactures must be-quality EMC directive on the complete installation again</p>		

Mechanical Specification

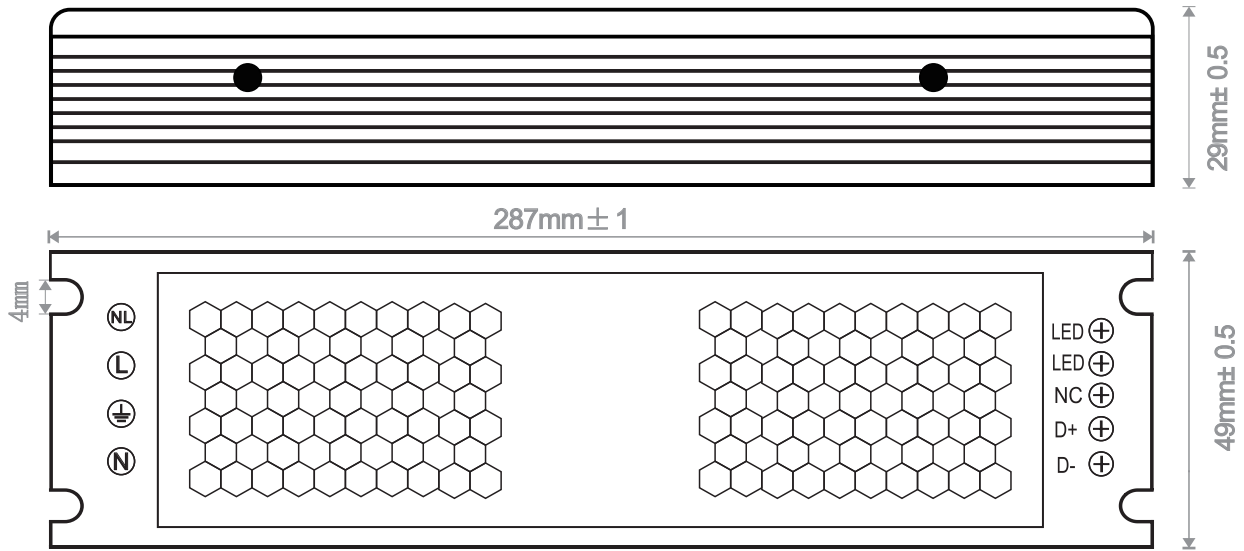

Derating Curve

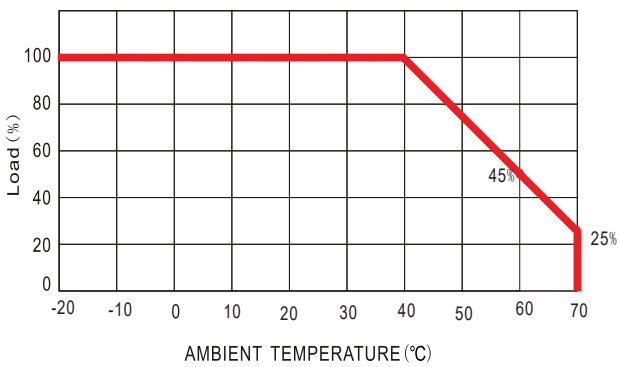

Package

DIMENSION	287x49x29 (mm) (L×W×H)
CARTON QUANTITY	50PCS/Carton
CARTON SIZE	370x300x29.5 (mm)
WEIGHT	360g /PCS

Switching Time Curve :

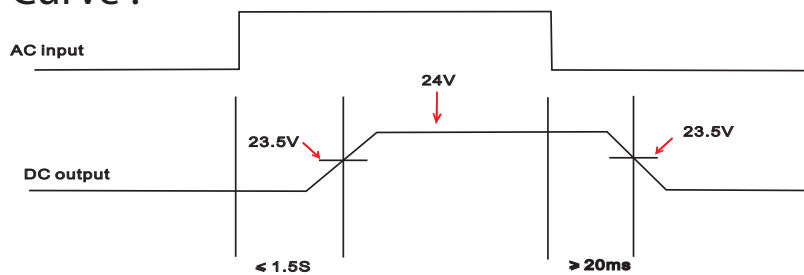

Dimming Operation

